

HXSP3T4081G SP3T Switch

1. Description

ID	Items	Specifications
1-1	Type	Absorptive SP3T Switch
1-2	Frequency Range	0.3GHz ~ 8.5GHz
1-3	Isolation	≥80dB
1-4	Insertion Loss	≤2.5dB
1-5	Amplitude Imbalance	≤0.5dB
1-6	VSWR	≤1.5
1-7	Impedance	50Ω
1-8	RF Input Power	2W
1-9	Switching Speed	≤200ns
1-10	Input/Output Connectors	SMA-F
1-11	Control Connectors	Φ0.8mm Glass Insulator
1-12	Control	TTL=0V/3.3V ~ 5V
1-13	DC Power Supply	+5V/≤150mA

2. Environmental Specifications

ID	Items	Specifications
2-1	Operational Temperature	-40℃ ~ +70℃
2-2	Storage Temperature	-55℃ ~ +85℃

3. Truth Table

ID	C2	C1	Signal Path State
3-1	0	0	J0-J1
	0	1	J0-J2
	1	0	J0-J3
	1	1	ALL OFF

4. Outline Drawing

ID	Items	Specifications
4-1	Outline Drawing	Unit: mm
Tolerances:±0.2mm		

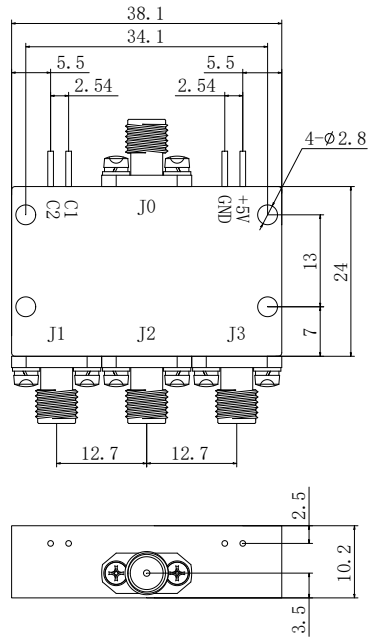

4-2	Material	Aluminum
4-3	Finish	Nickel Plated
4-4	Weight	60g

5. Note

5-1	Should be take the ESD protection during use.
5-2	Exceeding the rated input power limit may cause the product to burn out.
5-3	Avoid using in extreme temperature, humidity, or corrosive environments.
5-4	Good grounding can reduce EMI and RFI.
5-5	All specifications are subject to change without notice at any time.